

# THE ANNAPOLIS

2-4 BR | 2-3 FULL BA | 1-2 HALF BA | 2-CAR GARAGE



CRAFTMARK HOMES

BETTER HOMES. BETTER LIVING.

# First Floor

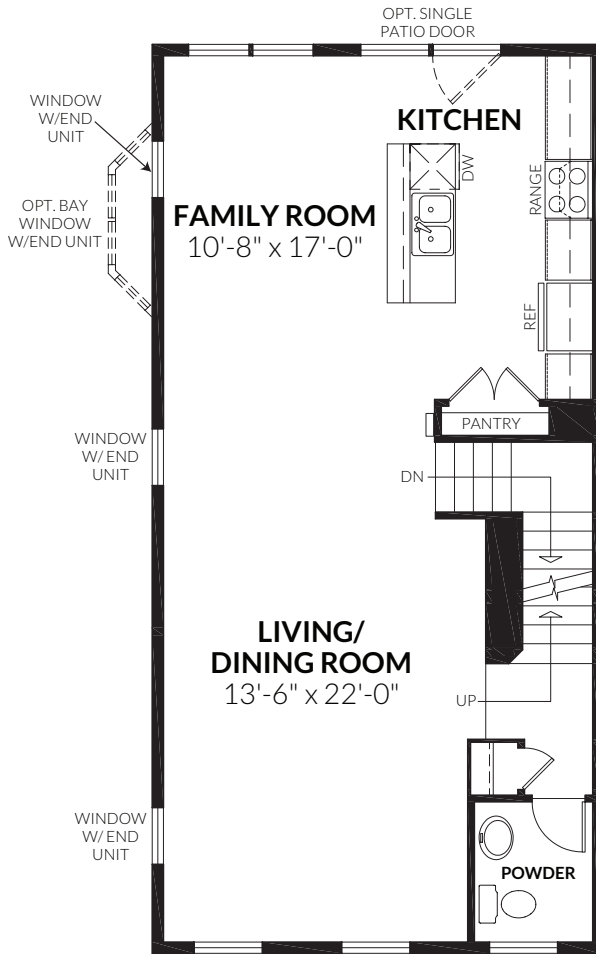

STANDARD FIRST FLOOR

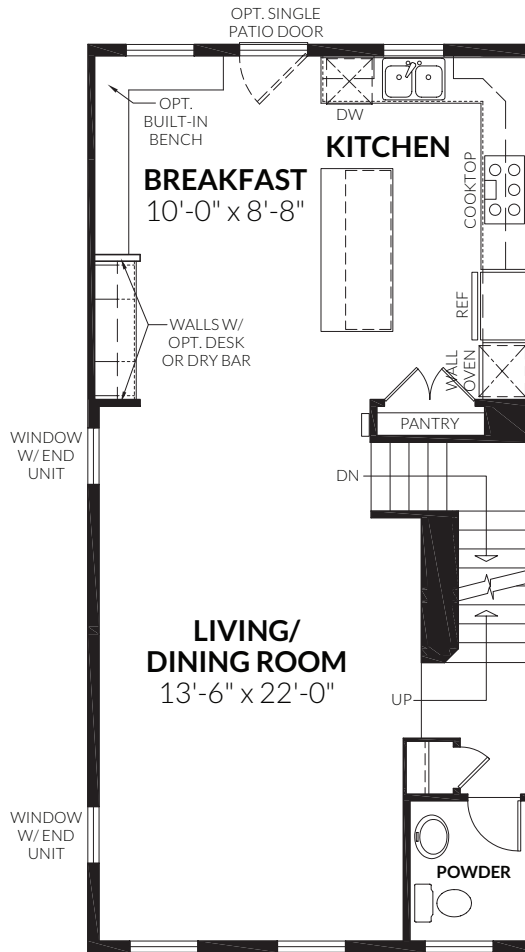

OPT. ALTERNATE FIRST FLOOR

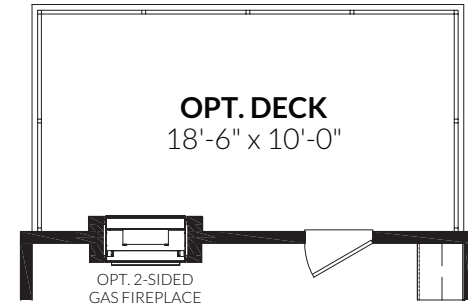

**OPT. GAS FIREPLACE WITH OPT. DECK**  
(N/A WITH ALTERNATE FIRST FLOOR)

# Second Floor

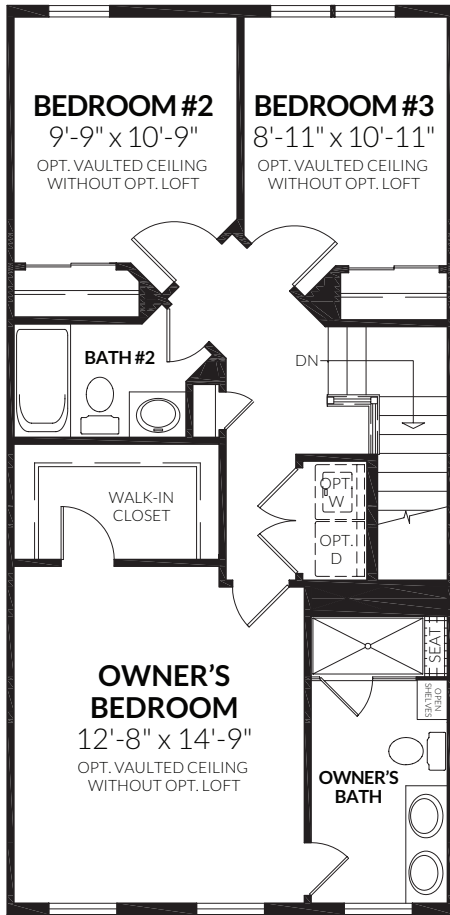

**STANDARD SECOND FLOOR**

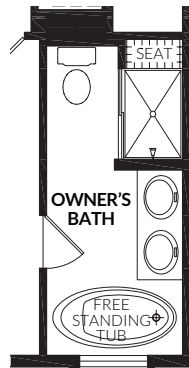

**OWNER'S BATH  
WITH OPT. TUB &  
SHOWER  
(N/A W/ LOFT)**

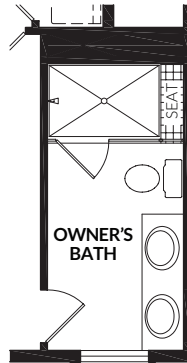

**OWNER'S BATH  
WITH OPT. LARGE  
SHOWER IN LIEU  
OF SHELVES  
(N/A W/ ALT.  
SECOND FLOOR)**

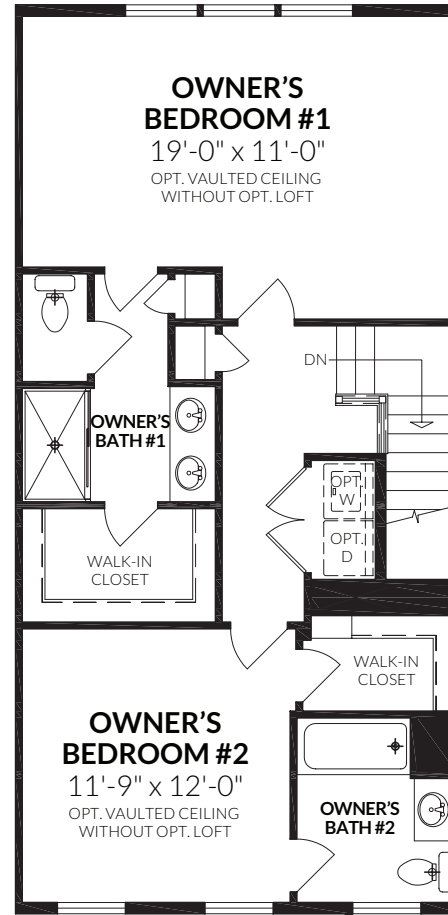

**OPT. ALTERNATE SECOND FLOOR**

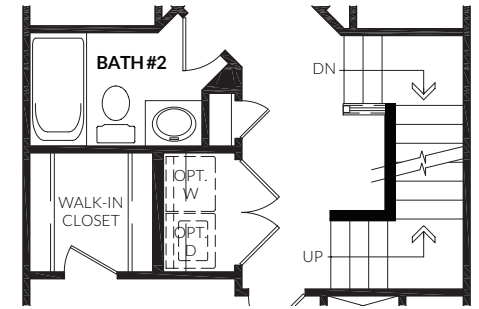

**SECOND FLOOR WITH OPT. LOFT\***

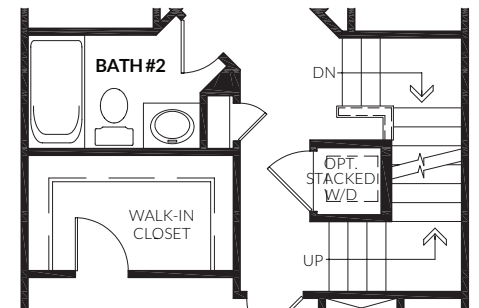

**SECOND FLOOR WITH OPT. LOFT\*  
WITH OPT. STACKED WASHER/DRYER**

CRAFTMARKHOMES.COM

All artist's renderings are concepts, may show optional features and are subject to change without notice. Ask Sales Manager for details.  
All floor plans and elevations are approximate and subject to change without notice. Room sizes and window configurations may vary with elevation.  
All dimensions noted represent widest point of room. Doors are not to scale and do not reflect actual door sizes.

# Ground Floor

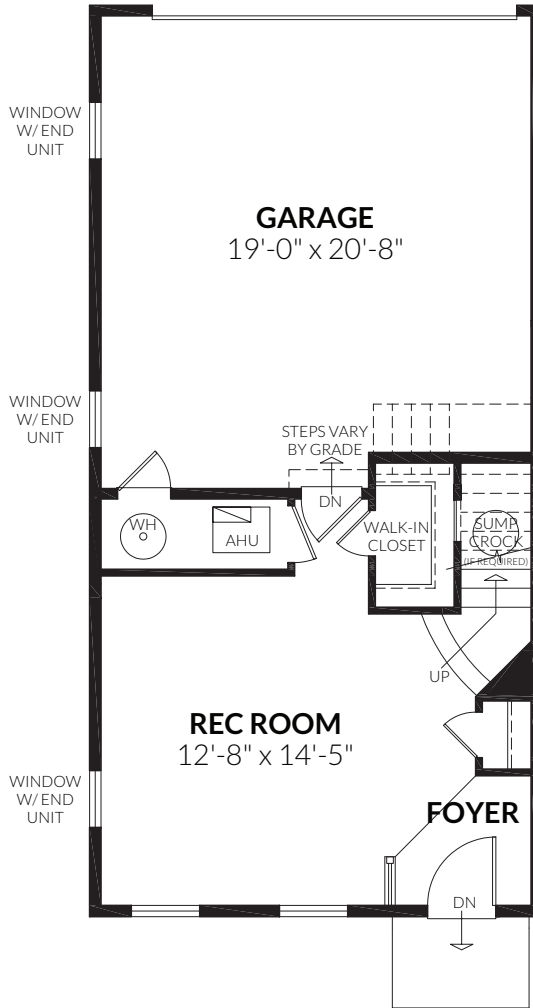

**STANDARD GROUND FLOOR**

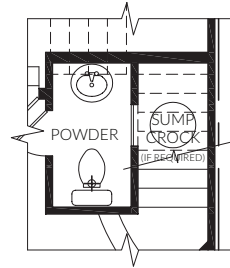

**OPT. POWDER ROOM**

# Optional Loft\*

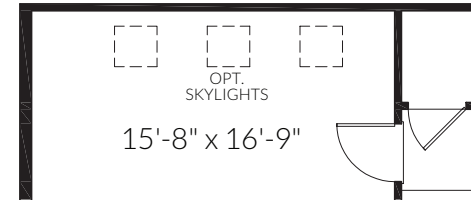

**OPT. LOFT BEDROOM & BATH\***  
(END CONDITION)



**OPT. LOFT BEDROOM & BATH\***

CRAFTMARKHOMES.COM



10/18  
MHBR# 451

All artist's renderings are concepts, may show optional features and are subject to change without notice. Ask Sales Manager for details. All floor plans and elevations are approximate and subject to change without notice. Room sizes and window configurations may vary with elevation. All dimensions noted represent widest point of room. Doors are not to scale and do not reflect actual door sizes. \*Loft bedrooms/baths are subject to availability set by jurisdictions.

